

TOP OF CONCRETE FOOTING SHALL BE PLACED FLUSH WITH FINAL ADJACENT SURFACE AND SHALL MATCH FINISH WHEN ADJACENT TO CONCRETE, SMOOTH OTHERWISE.

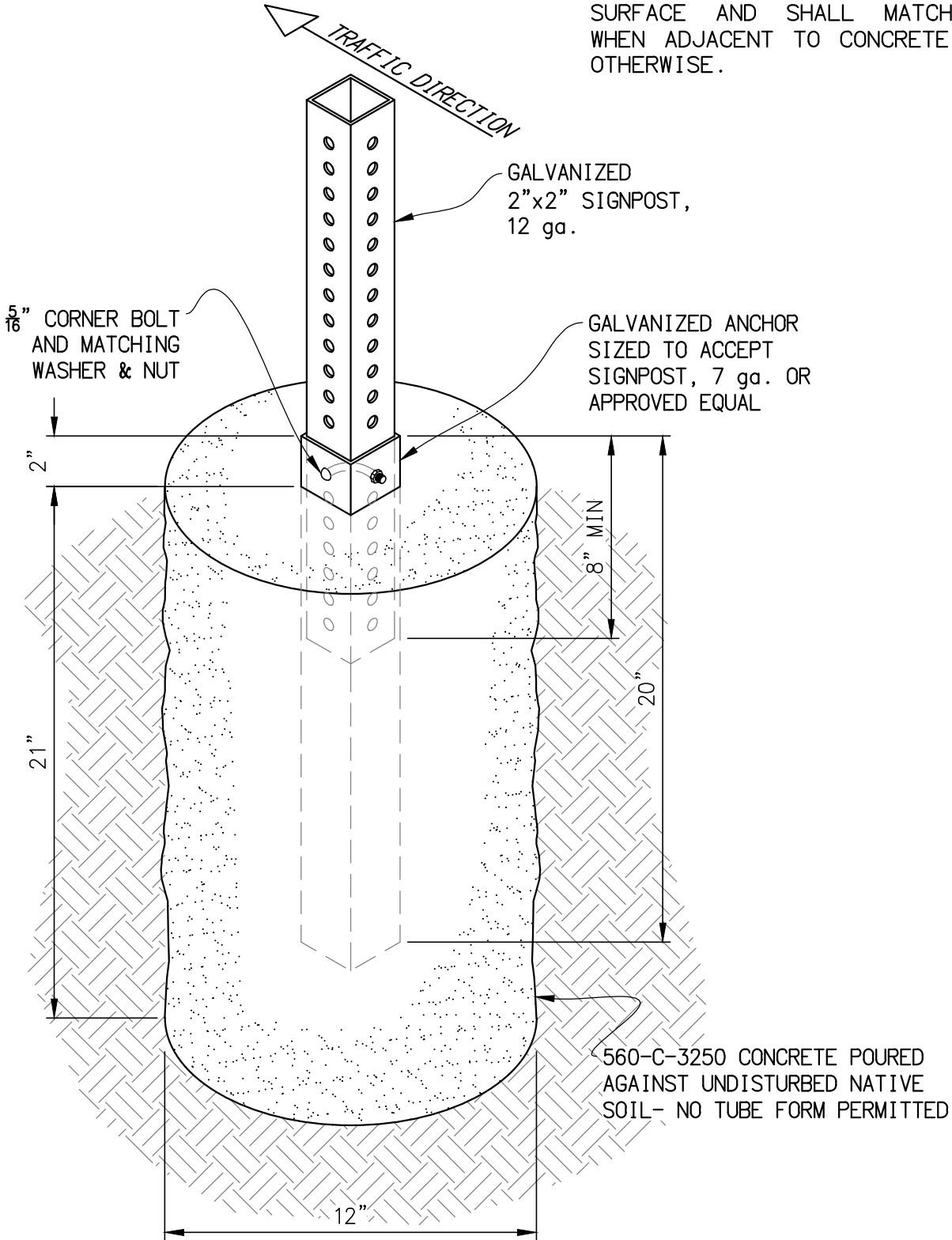

Public Works Department
550 E. 6th Street
Beaumont, CA 92223
(951) 769-8522
www.beaumontca.gov

**TRAFFIC SIGNPOST
INSTALLATION DETAIL**

APPROVED BY: *Jeff Hart*
JEFF HART, P.E., CITY ENGINEER
08/11/2021
DATE